



Series
NSX

T-CAS - SIZE 1 RF CONTACT
TIMES AA 5888 AND ECS 311601 CABLE
CRIMP TERMINAISON

Issue:
09 DEC 96

Page
1 / 1

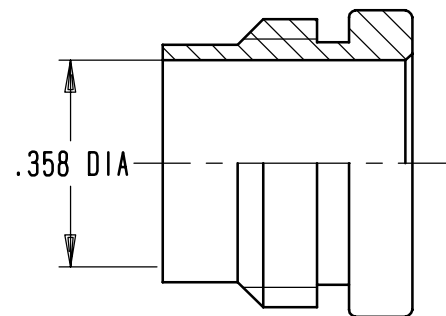
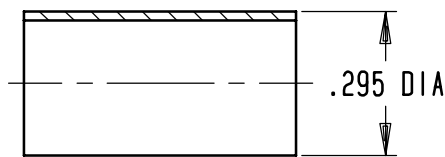
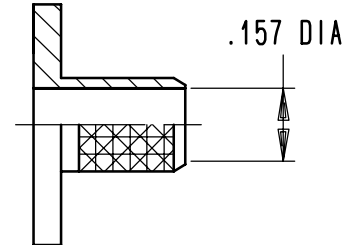
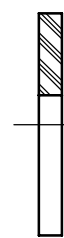
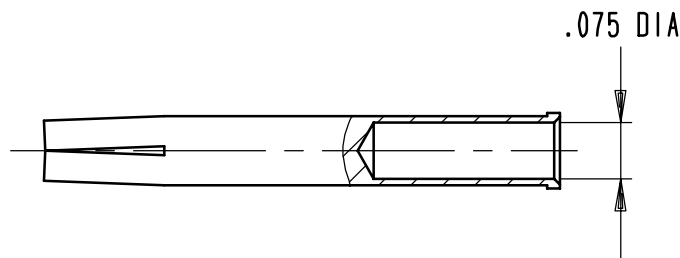
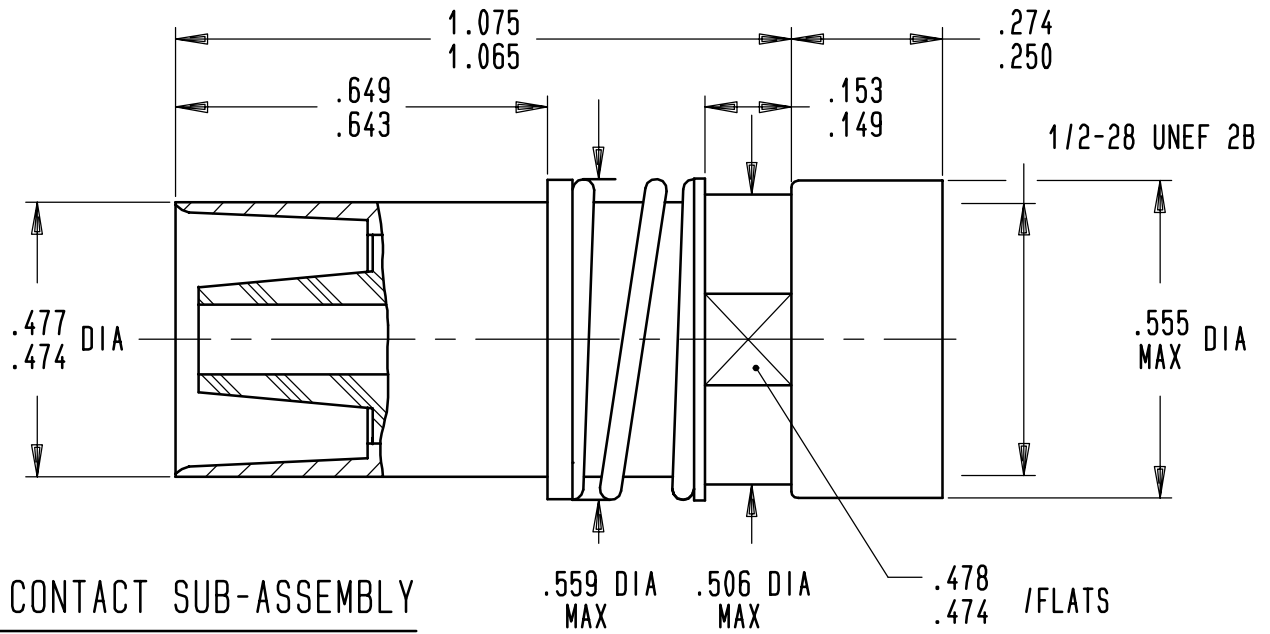

MATERIAL AND FINISH

CONTACT PARTS : COPPER ALLOY- .00005 INCH OF GOLD OVER NICKEL
SPRING: STAINLESS STEEL
C.CLIP: STEEL - NICKEL PLATED
WASHER: STAINLESS STEEL - PASSIVATED
DIELECTRIC AND DIELECTRIC WASHER: TEFLON

WIRING INSTRUCTIONS : RP 6178

4112-9610

CREATION				
PEN: .				
NOM: FALETTI				
DATE: 07 OCT 91				
APPR.: .	09 DEC 96	REDRAWN	VALGRESY	.
	Issue	Revisions	Name	Approved